



# Dictation

Handwriting practice lines consisting of solid top and bottom lines with a dashed midline, repeated 10 times down the page.



## *Institutes for Excellence in Writing Charts*

Adapted with permission for use with IEW: Teaching Writing: Structure and Style by Andrew Pudewa

\_\_\_\_\_  
(Title)  
By  
\_\_\_\_\_

I. \_\_\_\_\_

1. \_\_\_\_\_

2. \_\_\_\_\_

3. \_\_\_\_\_

4. \_\_\_\_\_

5. \_\_\_\_\_

# ***Institutes for Excellence in Writing Charts***

Refer to page 7 and 11 of the IEW workbook for explanations of these charts.

## **Outline**

**I.**

**1.**

**2.**

**3.**

**II.**

**1.**

**2.**

**3.**

**3 Words**

**Max**

**Double Space!**

**Double Space!**



**Indentation**

**CAPITALS and . ? , !**



# Institutes for Excellence in Writing Chart

Refer to page 18-20 of the IEW workbook for an explanation of how to use this chart.

## The Banned Word List

~~Say~~

~~Said~~

intone  
exclaim  
assert  
cried out  
screech  
stammered  
shouted  
yelled

~~get~~

obtain  
acquire  
capture  
solicit  
seize  
grab  
confiscate  
purchase

~~See~~

observe  
inspect  
notice  
view

~~Like~~

enjoy  
savor  
crave  
taste  
luxuriate  
relish  
bask  
treasure

~~nice~~

agreeable  
decorous  
refined  
fitting  
gentle  
dainty  
pleasant  
peaceful  
enjoyable  
lovely

~~eat~~

devour  
ingest  
consume  
nibble  
gnaw

~~go~~

rush  
journey  
tour  
trek  
advance  
depart  
flee  
abscond

~~pretty~~

beautiful  
magnificent  
alluring  
gorgeous  
comely  
handsome

~~big~~

capacious  
immense  
gargantuan  
enormous



# Institutes for Excellence in Writing Chart

Refer to pages 18-21 of the IEW workbook for an explanation of how to use this chart.

## Adverbs

### I

#### Importance

entirely  
significantly  
fundamentally  
substantially  
essentially  
primarily  
absolutely  
relatively  
seriously  
distinctly  
utterly  
notably  
typically

### II

#### Assurance

completely  
presumably  
predictably  
probably  
undeniably  
normally  
tentatively  
willingly  
assuredly  
strictly  
possibly  
obviously  
evidently  
surely

### III

#### Frequency

rapidly  
frequently  
continuously  
increasingly  
occasionally  
repeatedly  
regularly  
normally  
constantly  
slowly  
confidently  
gradually  
usually  
steadily

### IV

#### Sequence

#### Avoid

firstly  
secondly  
thirdly

#### Choose

initially  
eventually  
ultimately  
originally  
effectively  
finally

#### Sometimes use

previously  
progressively  
consequently

### V

#### Others

easily  
dramatically  
virtually  
suddenly  
simply  
silently

### VI

#### Emotion

un/happily  
sadly  
tragically  
stubbornly  
eagerly  
wistfully  
un/fortunately  
in/conveniently  
proudly  
carefully  
hopefully  
mournfully



# Institutes for Excellence in Writing Chart

Refer to pages 17-19 of the IEW workbook for an explanation of how to use this chart.

## Quality Adjectives

<u>Good</u>	<u>Great</u>	<u>Bad</u>	<u>Pretty</u>	<u>Nice</u>	<u>Big</u>	<u>Interesting</u>
great	extraordinary	wicked	beautiful	kind	huge	amazing
terrific	marvelous	immoral	majestic	delightful	colossal	astonishing
magnificent	excellent	dishonest	stunning	pleasant	towering	miraculous
exquisite	super	harsh	lovely	charming	massive	incredible
majestic	wonderful	evil	glorious	sweet	gigantic	remarkable
flourishing	splendid	sinister	glowing	sympathetic	broad	intriguing
powerful	exemplary	rebellious	golden	genial	immense	fascinating
respectable	awesome	villainous	lush	agreeable	monstrous	exciting
praiseworthy	fascinating	unscrupulous	elegant	enchanted	spacious	captivating
admirable	superb	impious	enticing	amiable	monumental	puzzling
courageous	glorious	dissolute	glorious	agreeable	vast	baffling
mighty	spectacular	licentious	exquisite	affectionate	enormous	mysterious
clever	capital	roguish	ornate	cordial	expansive	remarkable
wise	unequaled	crooked	attractive	cooperative	extensive	amusing
prudent	unparalleled	untrustworthy	handsome	sympathetic	mammoth	gripping
commend- able	outstanding	disloyal	fancy	<u>Ugly</u>	substantial	exciting
skillful	unrivaled	treasonous	captivating	mutilated	stupendous	tantalizing
adept	exquisite	insidious	gorgeous	gruesome	gargantuan	enthraling
virtuous	wholesome	deceitful	ravishing	scary	prodigious	baffling
moral	nutritious	sinister	alluring	hideous	grandiose	
righteous	beneficial	sinful	ornate	appalling	prominent	
honest	favorable	criminal	<u>Mean</u>	grotesque	<u>A Lot</u>	<u>Small</u>
noble	advantageous	base	ruthless	deformed	several	tiny
wholesome	worthwhile	unreliable	cruel	repulsive	numerous	little
pure	profitable	wily	hard- hearted	frightening	plenty	diminutive
innocent	delicious	sly	savage	creepy	countless	petite
untainted	delectable	dishonest	uncaring	shocking	multiple	miniature
saintly	scrumptious	heinous	heartless	disturbing	innumera- ble	miniscule
courteous	flavorful	spiteful	overbear- ing	unsightly	a myriad	puny
obedient	tasty	brutal	diabolical	unattractive	endless	minute
trustworthy	appetizing	atrocious	atrocious	blemished	countless	stunted
upstanding	savory	abominable	abominable	marred	multiple	dwarf
upright	capable	detestable	detestable	gruesome	abundant	thin
	efficient			homely	profuse	slender
				contorted	copious	lean
						spare



---

## ***China and Confucius Test***

*(from Chapter 32, 33 of The Story of the World: Ancient Times)*





1. What is Chinese writing called?
2. How did calligraphers make their brushes?
3. How did the Chinese begin printing?
4. Describe the period of time called the “Warring States”.
5. Who was Qin Zeng?
6. Why did Qin Zeng Build the Great Wall of China?
7. What did two men find when they were digging?
8. What did Confucius teach his people?
9. What were the “Analects of Confucius”?

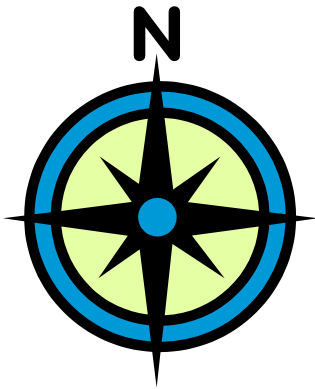

# Geography Ideas



**Key:**

	River
	Mountain
	Lake
	Fertile land

**Phoenician Product Map**

	Ivory
	Glass
	Salt
	Gold
	Copper
	Silver
	Olive Oil
	Lead
	Wood

## **Books of the New Testament**

Matthew  
Mark  
Luke  
John  
Acts  
Romans  
I Corinthians  
II Corinthians  
Galatians  
Epehsians  
Philippians  
Colossians  
I Thessalonians  
II Thessalonians  
I Timothy  
II Timothy  
Titus  
Philemon  
Hebrews  
James  
I Peter  
II Peter  
I John  
II John  
III John  
Jude  
Revelation

Here is the music to sing the Books of the NT to:

[www.wholesomewords.org/family/kjvbkssong.html](http://www.wholesomewords.org/family/kjvbkssong.html)

If you just want to listen to the song here is a site that will sing it for you. Click on number 13 under 1<sup>st</sup> grade: <http://64.185.28.227/memory-work.htm>



# Trireme Drawing

This boat is complicated, but it is doable. Have your child only draw the detail appropriate for their age level. For young children only have them color the finished boat.

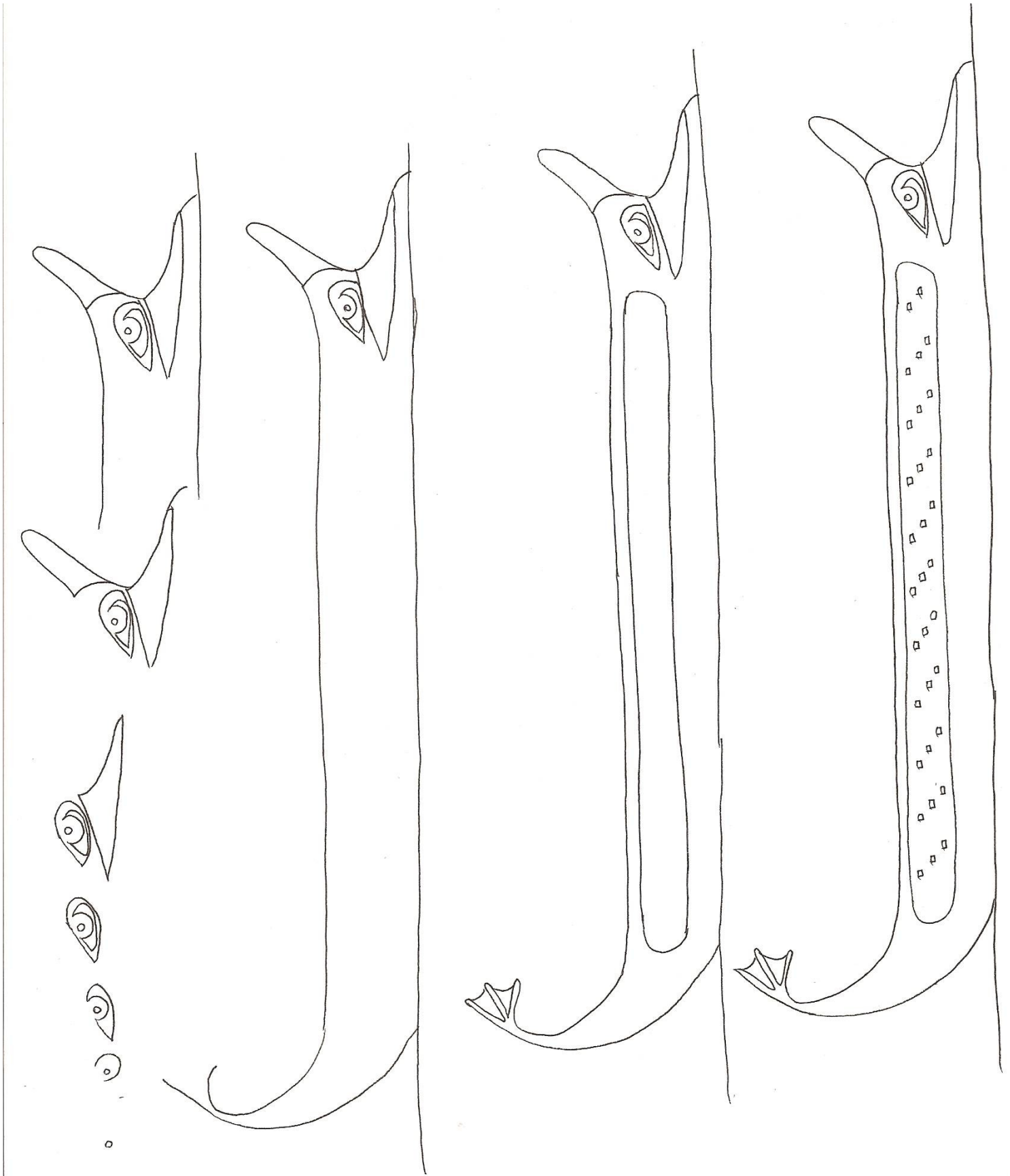

# Trireme Drawing Continued

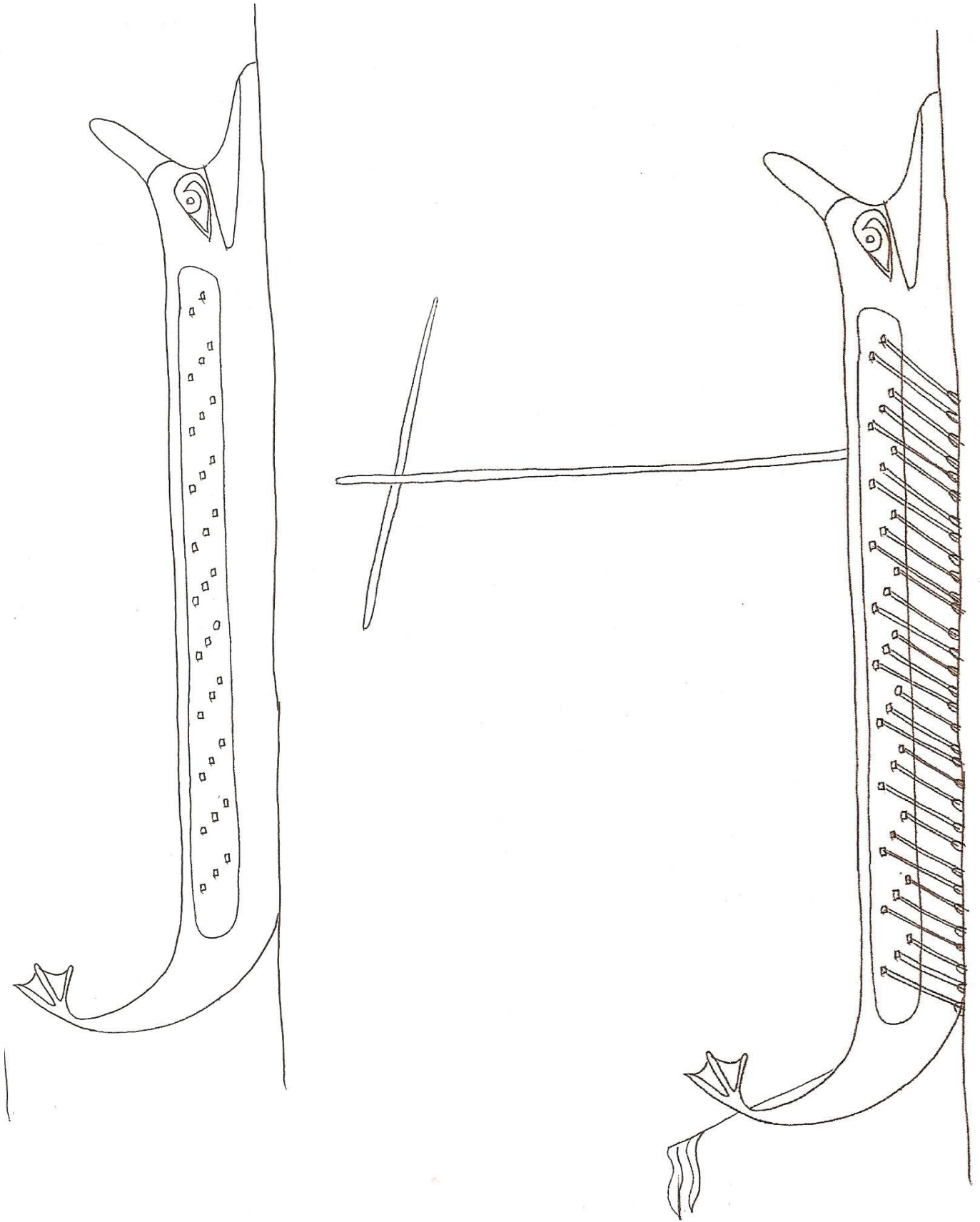

# Trireme Drawing Continued

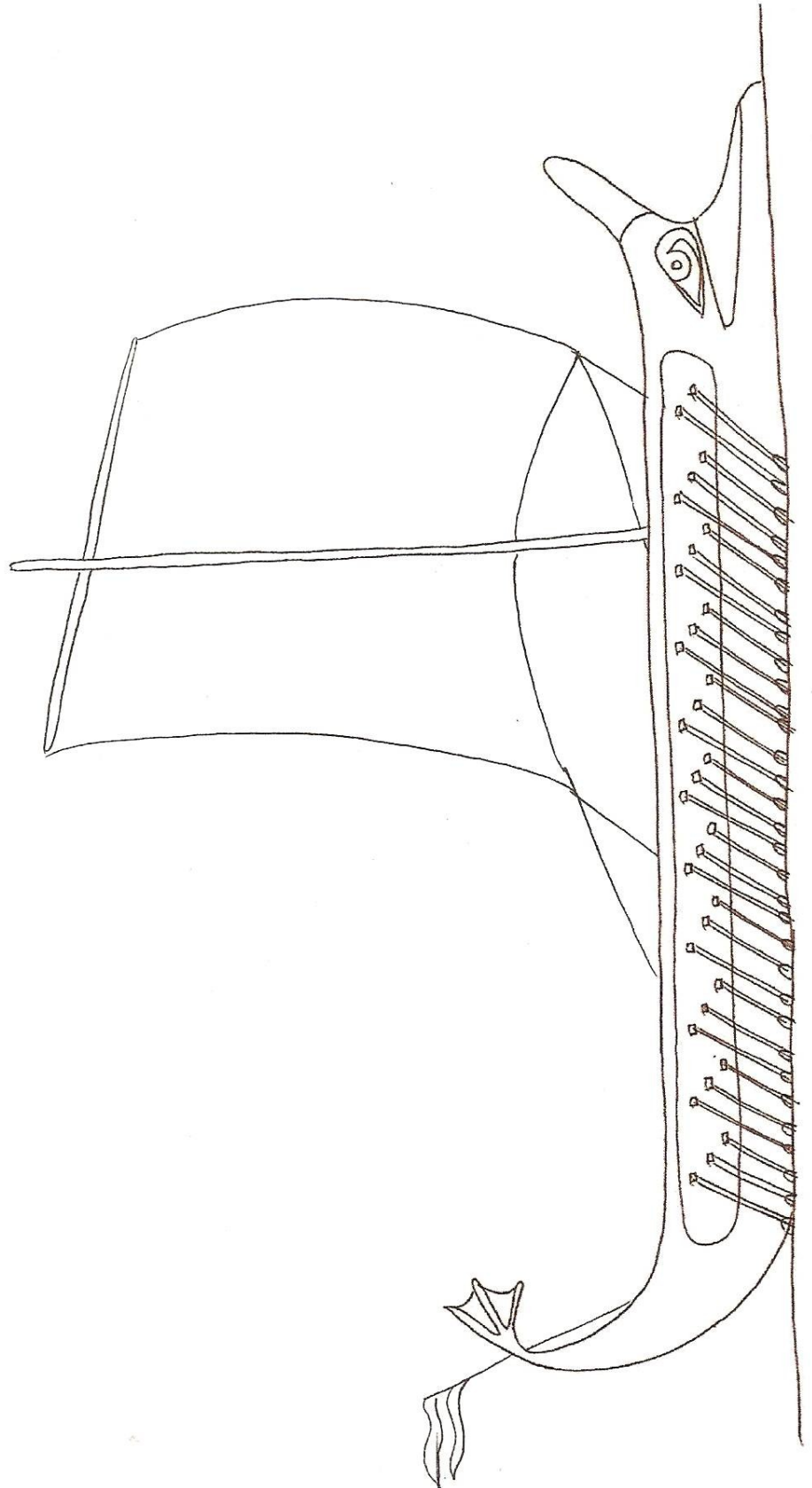

## Trireme Drawing Continued

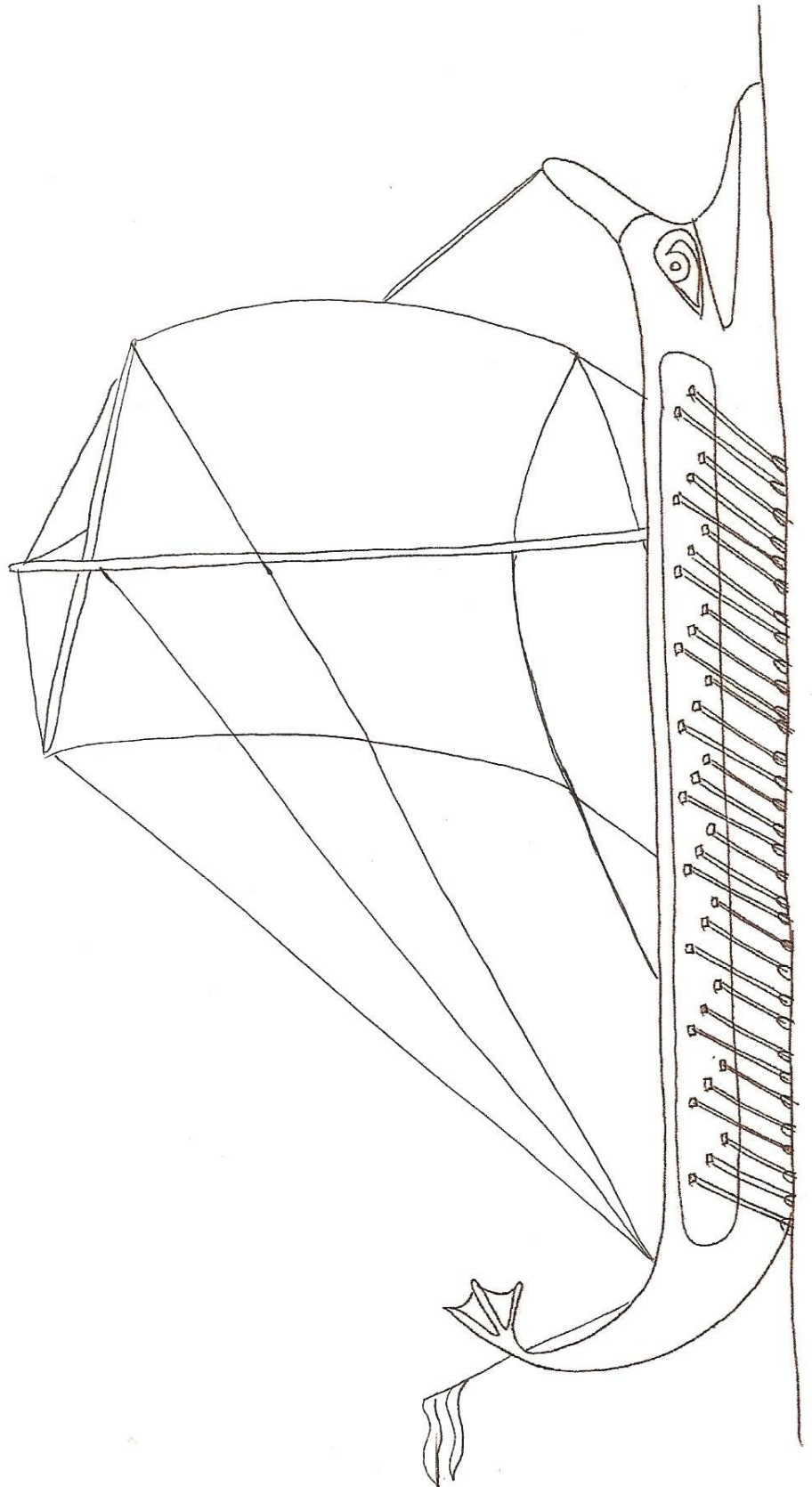

## ***Trireme Drawing Continued***

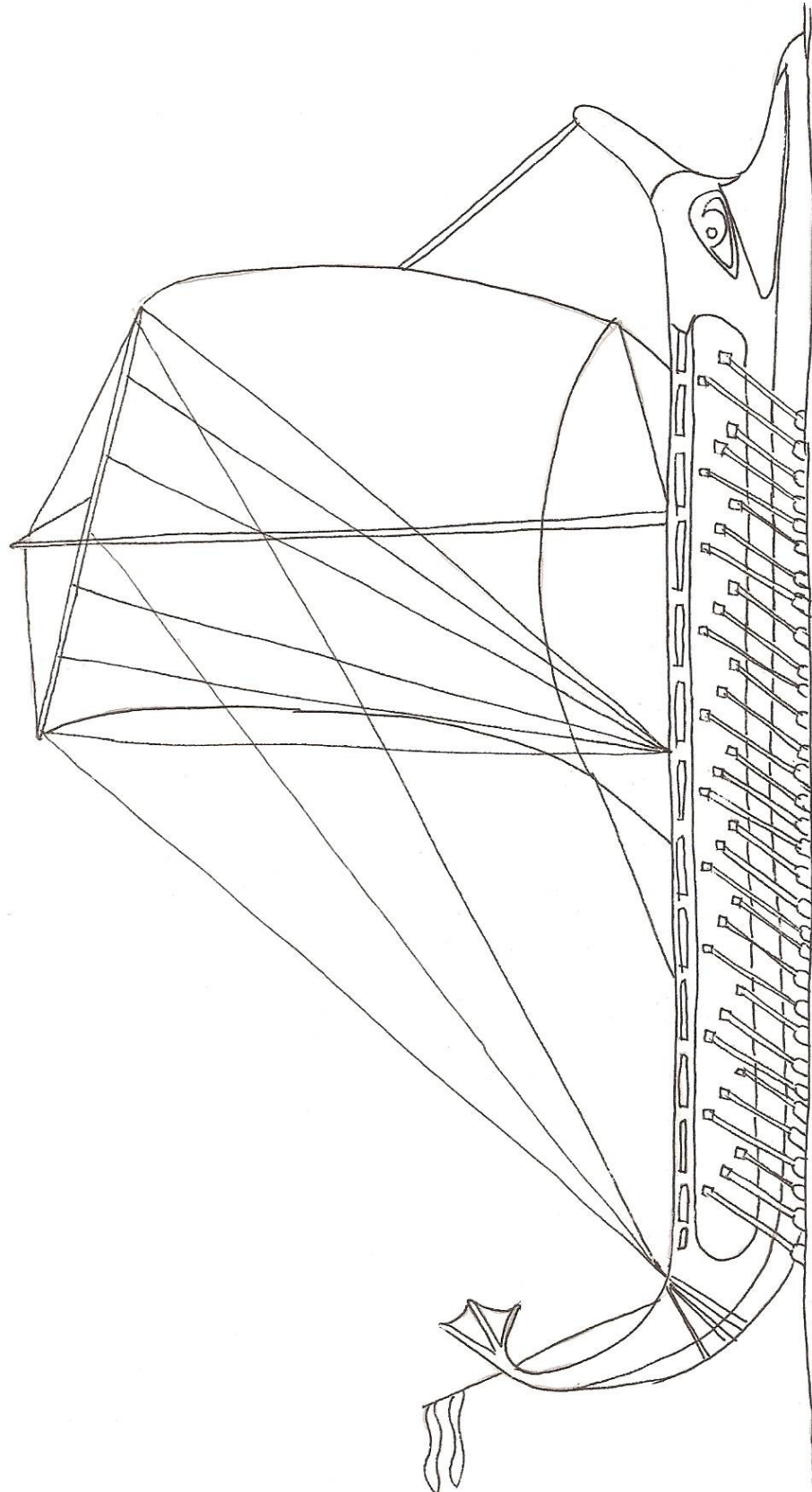



# Science Summary Sheet

This area is for a drawing of the science topic you are studying.

Handwriting practice area consisting of multiple sets of horizontal lines. Each set includes a solid top line, a dashed midline, and a solid bottom line.



# Science Experiment Sheet

This area is for a drawing of the experiment.

What we used:

---

---

---

---

---

---

---

---

What we did:

---

---

---

---

---

---

---

---

What happened?

---

---

---

---

---

---

---

---

---

---

What we learned:

---

---

---

---

---

---

---

---

---

---

## Molecule Building Activity

- 1) Look at paper included in your Student Molecular Model Set. Determine which colors represent which elements.
- 2) Look at the atom models and note the number of holes in each. When you make a model, you **MUST** fill up each hole with a bond. For example, black represents carbon and each carbon sphere has four holes. To make correct structures, you **MUST** fill all four.
- 3) Make the following molecules:  $H_2$ ,  $O_2$  and  $N_2$ . These three demonstrate the use of single, double and triple bonds.
- 4) Now, make  $H_2O$  and  $NH_3$ . Both of these molecules use only single bonds.
- 5) Now, make  $CO_2$  and  $HCN$ . The first uses two double bonds and the second uses one triple bond and one single bond.
- 6) Now, make methane:  $CH_4$  and  $C_2H_4$ . Both of these molecules use single bonds.
- 7) When you are finished making your models check them with the pictures on the next page.

Note: if you are using gum drops and toothpicks instead of the molecular kit here is a list of corresponding colors:

Red: represents Oxygen atoms  
Yellow: represents Hydrogen atoms  
Blue: represents Nitrogen atoms  
Black: represents Carbon atoms

## Molecule Building Activity Answers

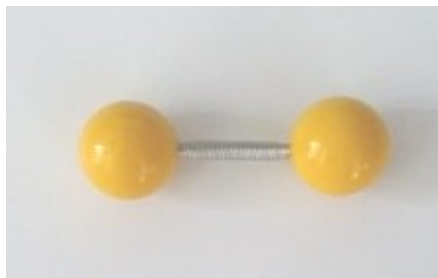

$\text{H}_2$



$\text{O}_2$



$\text{N}_2$

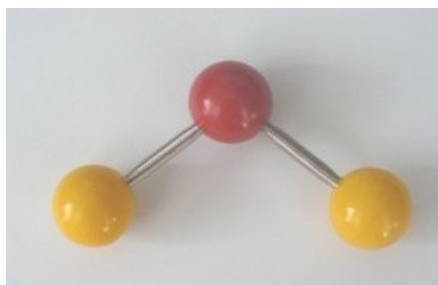

$\text{H}_2\text{O}$

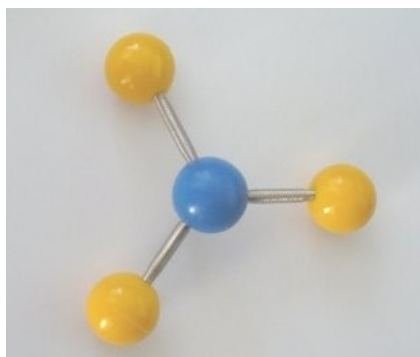

$\text{NH}_3$



$\text{HCN}$

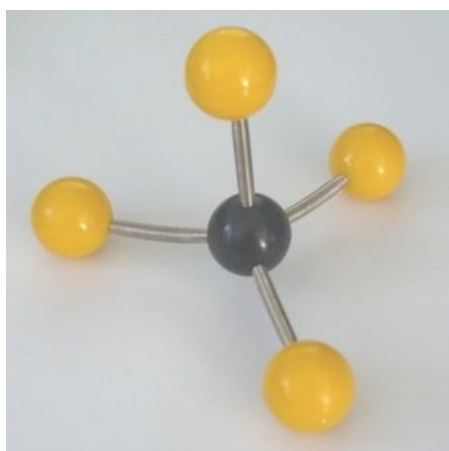

$\text{CH}_4$